

Floor-standing water storage tanks OKC NTR(R), OKC NTR/HV, OKH NTR/HV

OKC 100-250 NTR(R)

- Capacities of 100–250 l
- Two exchangers possible for volumes of from 200 l and up
- Service water inlet and outlet through top lid for capacities of 100–160 l
- Capacities of 100–160 l have discharge outlet



OKC 100–160 NTR OKC 200, 250 NTR

Types of storage tanks		OKC 100 NTR	OKC 125 NTR	OKC 160 NTR	OKC 200 NTR(R)	OKC 250 NTR(R)
Capacity	[l]	87	112	148	208 (200)	242 (234)
Weight of the empty water heater	[kg]	53	66	73	93 (102)	95 (104)
Insulation thickness	[mm]			42		
Thermal conductivity of the insulation	[W·m ⁻¹ ·K ⁻¹]			0,022		
Max. working temperature / overpressure in tank	[°C]/[bar]			90/6		
Heat transfer surface of the exchanger* (top/bottom)	[m ²]	1,08	1,45	1,45	1,45 (1/1)	1,45 (1/1)
Capacity of the exchanger* (top/bottom)	[l]	7,1	9,5	9,5	9,5 (7/7)	9,5 (7/7)
Max. working temperature / overpressure in tank	[°C]/[bar]			110/10		
Power of the exchanger at the 720 l at 80 °C *	[kW]	24	32	32	32 (24/24)	32 (24/24)
Heating time by the exchanger from 10 °C to 60 °C *	[min]	13	12	16	23 (14/14)	26 (14/23)
Energy efficiency class		B	C	C	C	C
Static loss	[W]	42	54	75	82	87

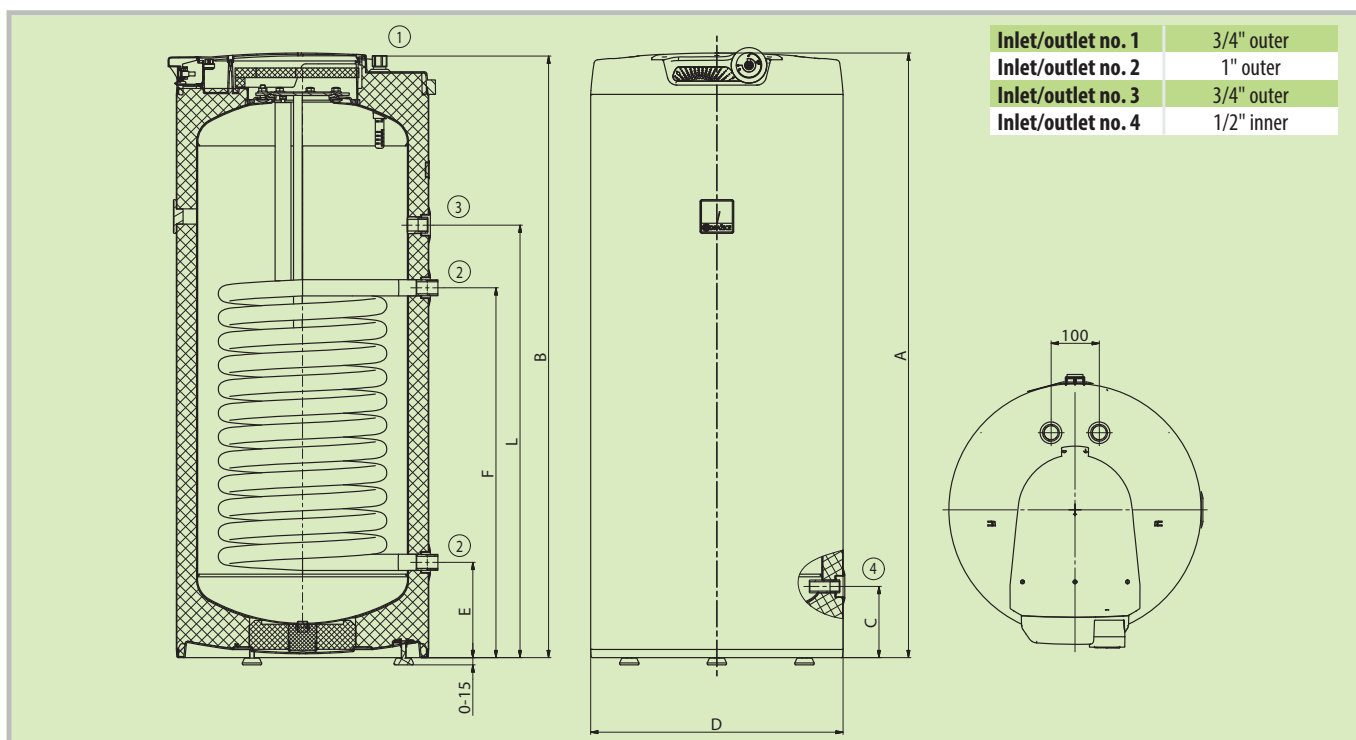

Dimensions [mm]	A	B	C	D	E	F	L
OKC 100 NTR	902	891	147	524	197	637	537
OKC 125 NTR	1064	1058	147	524	197	767	637
OKC 160 NTR	1255	1249	147	524	197	767	897

Floor-standing water storage tanks OKC NTR(R), OKC NTR/HV, OKH NTR/HV

OKC 200–250 NTR

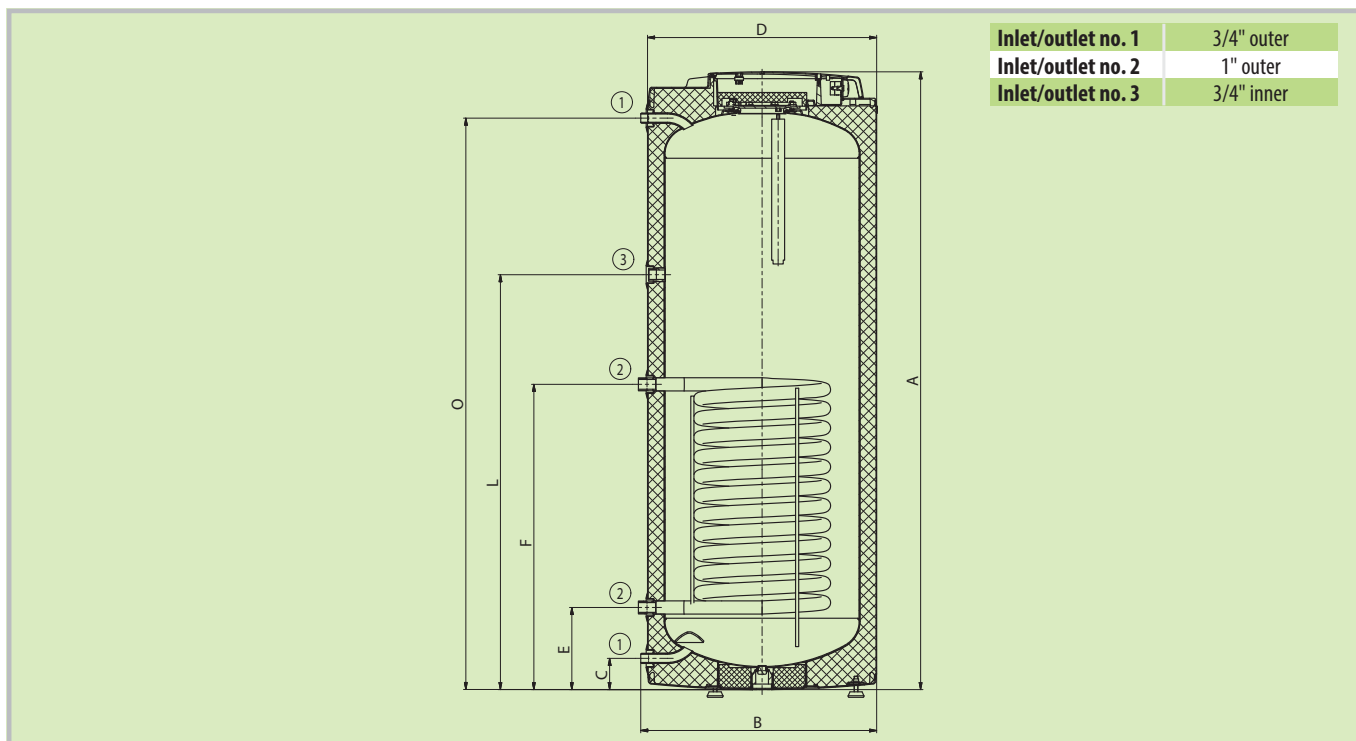

Dimensions [mm]	A	B	C	D	E	F	L	O
OKC 200 NTR	1398	603	80	585	210	780	950	1280
OKC 250 NTR	1578	603	80	585	210	780	1060	1460

OKC 200–250 NTRR

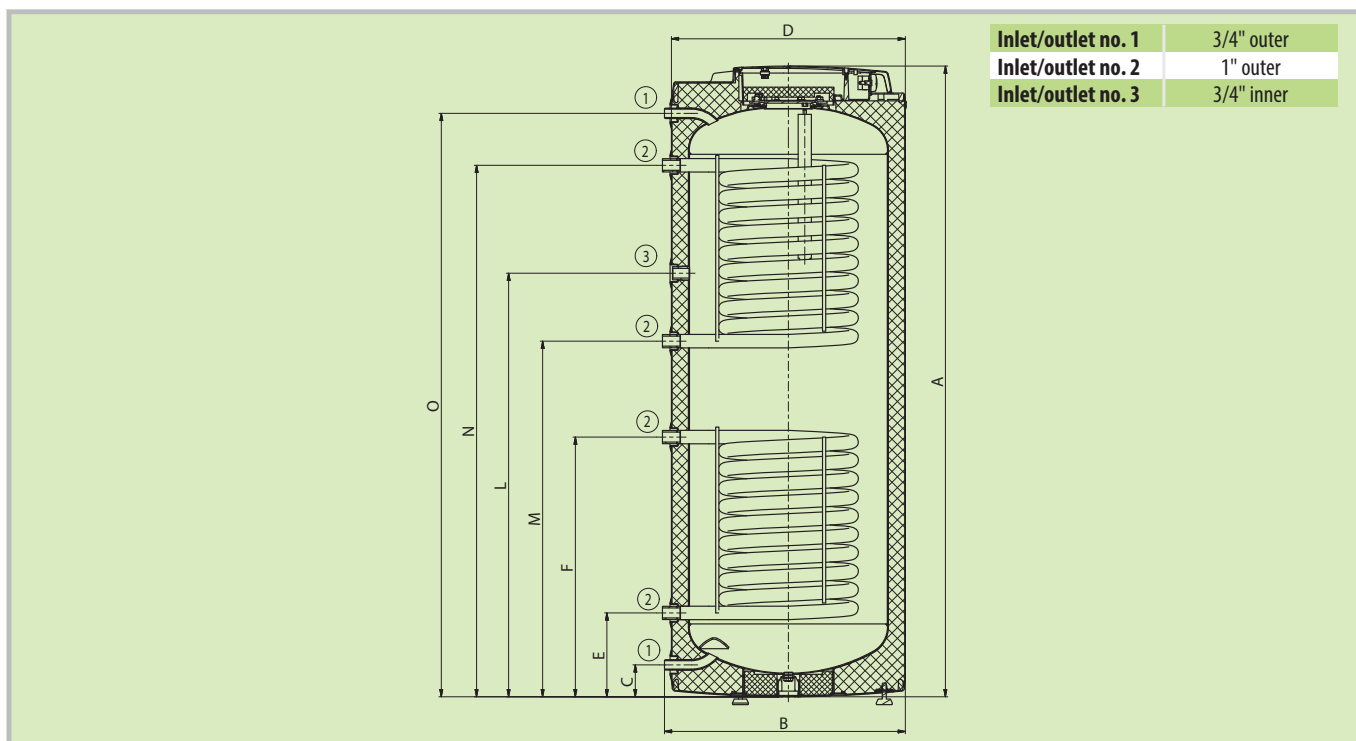

Dimensions [mm]	A	B	C	D	E	F	L	M	N	O
OKC 200 NTRR	1398	603	80	585	210	650	950	710	1150	1280
OKC 250 NTRR	1578	603	80	585	210	650	1060	890	1330	1460

Floor-standing water storage tanks OKC NTR(R), OKC NTR/HV, OKH NTR/HV

OKC 100–160 NTR/HV

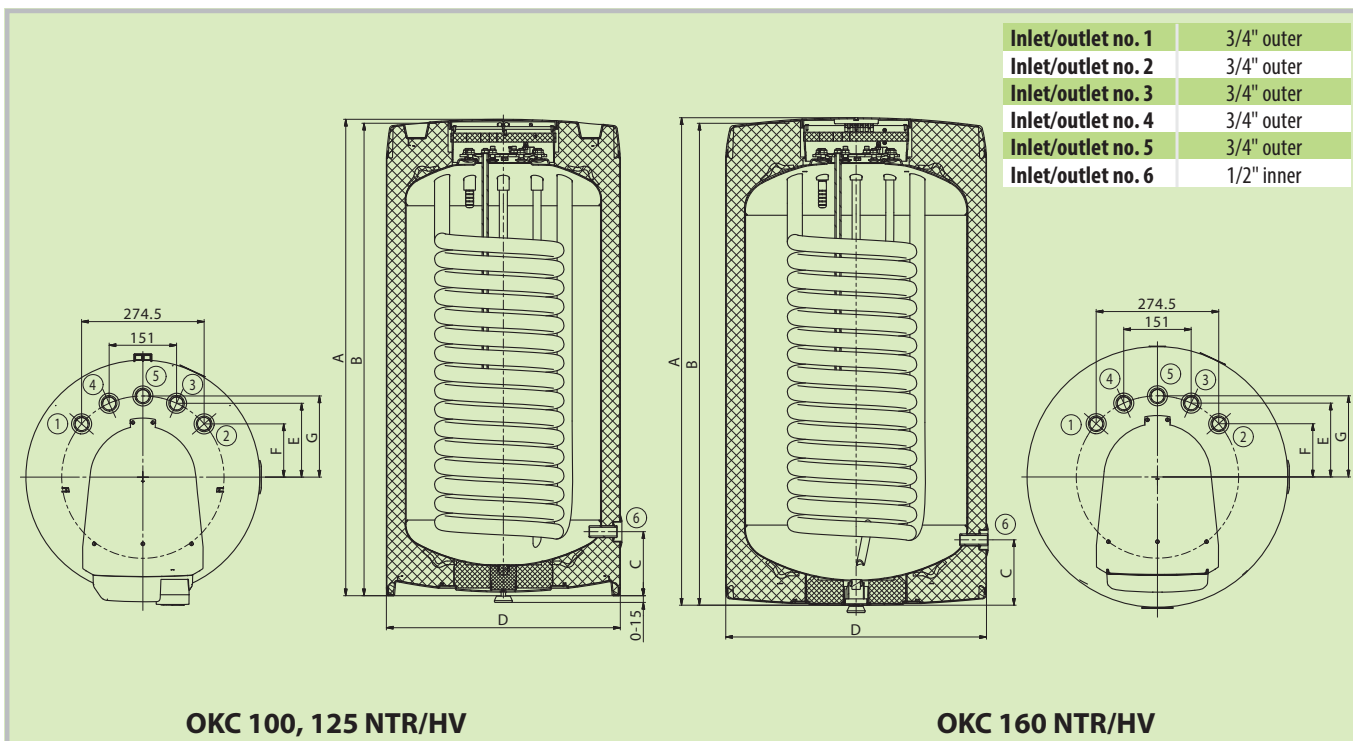

Dimensions [mm]	A	B	C	D	E	F	G
OKC 100 NTR/HV	902	893	144	524	165	119	182
OKC 125 NTR/HV	1067	1058	144	524	165	119	182
OKC 160 NTR/HV	1092	1079	146	584	165	119	182

OKH 100–125 NTR/HV

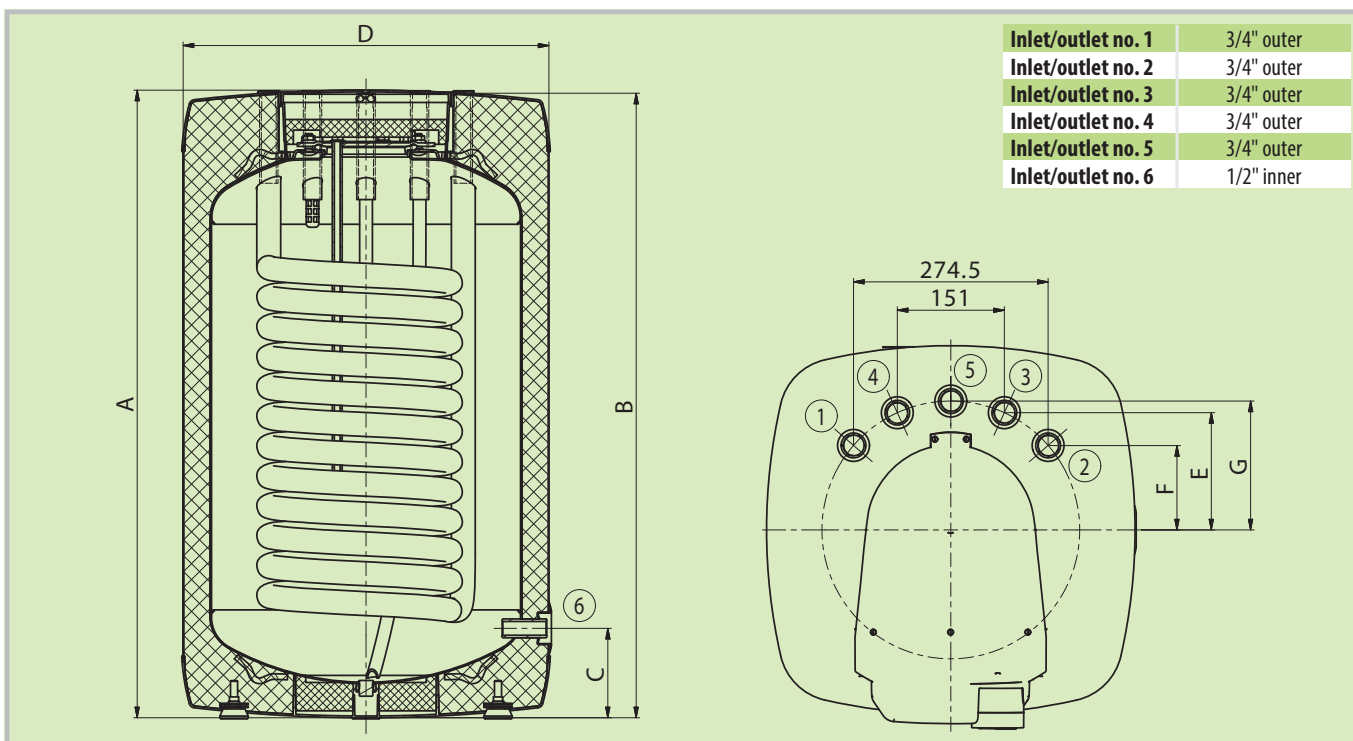

Dimensions [mm]	A	B	C	D	E	F	G
OKH 100 NTR/HV	885	882	127	520	165	119	182
OKH 125 NTR/HV	1050	1047	127	520	165	119	182

Floor-standing water storage tanks OKC NTR(R), OKC NTR/HV, OKH NTR/HV

OKC 100–160 NTR/HV

- Capacities of 100–160 l
- Inlets and outlets of all media through the top lid
- Storage tanks suitable for installation under wall-mounted boilers
- Storage tanks have discharge outlet enclosed



OKC 100, 125 NTR/HV

OKC 160 NTR/HV

Types of storage tanks		OKC 100 NTR/HV	OKC 125 NTR/HV	OKC 160 NTR/HV
Capacity	[l]	87	113	144
Weight of the empty water heater	[kg]	53	64	77
Insulation thickness	[mm]		42	
Thermal conductivity of the insulation	[W·m ⁻¹ ·K ⁻¹]		0,022	
Max. working temperature / overpressure in tank	[°C]/[bar]		90/6	
Heat transfer surface of the exchanger *	[m ²]	1,08	1,45	1,45
Capacity of the exchanger *	[l]	7,1	9,5	9,5
Max. working temperature / overpressure in tank	[°C]/[bar]		110/10	
Power of the exchanger at the 720 l at 80 °C *	[kW]	24	32	32
Heating time by the exchanger from 10 °C to 60 °C *	[min]	13	12	16
Energy efficiency class		B	C	C
Static loss	[W]	42	65	65

OKH 100–125 NTR/HV

- Capacities of 100–125 l
- Inlets and outlets of all media through the top lid
- Storage tanks suitable for installation under wall-mounted boilers
- Storage tanks have discharge outlet enclosed



Types of storage tanks		OKH 100 NTR/HV	OKH 125 NTR/HV
Capacity	[l]	87	115
Weight of the empty water heater	[kg]	55	67
Insulation thickness	[mm]		to 80
Thermal conductivity of the insulation	[W·m ⁻¹ ·K ⁻¹]		0,022
Max. working temperature / overpressure in tank	[°C]/[bar]		90/6
Heat transfer surface of the exchanger *	[m ²]	1,08	1,45
Capacity of the exchanger *	[l]	7,1	9,5
Max. working temperature / overpressure in tank	[°C]/[bar]		110/10
Power of the exchanger at the 720 l at 80 °C *	[kW]	24	32
Heating time by the exchanger from 10 °C to 60 °C *	[min]	13	13
Energy efficiency class		B	B
Static loss	[W]	44	49

Note: * Value is determined by calculation

Contact: